

サタケマルチ S ミキサー (S3~S9 シリーズ)

側面形 (ギヤ 1 段減速)

標準攪拌翼 : AF100 インペラ(1 段)

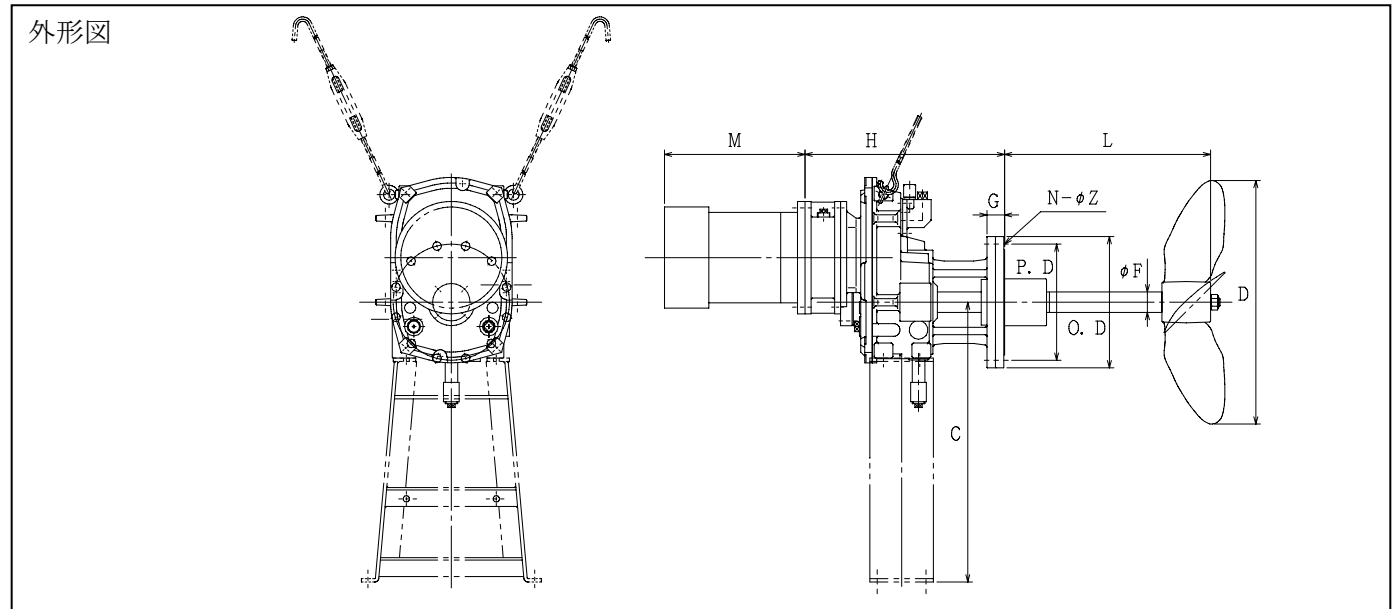

標準寸法表

	シリーズ No.	回転数 [min ⁻¹]	モータ動力 [kW]	極数 [P]	寸法 [mm]										ミキサー本体概算質量 [kg]												
					O. D	P. D	N	Z	G	F	L	H	C	M	D	モータ質量											
1 段 減 速	S 3	350	5.5	4	350	310	12	23	47	55	550	533	750	400	500	260	80										
			7.5	4										400	530	260	80										
			5.5	4										400	530	260	80										
		280	7.5	6										400	600	265	80										
			3.7	6										400	500	260	80										
			5.5	6										400	530	260	80										
		230	3.7	6										400	590	265	80										
			5.5	6										400	650	270	80										
			11	4										485	590	360	110										
		S 4	350	15										4	400	355	12	25	51	65	650	604	890	525	630	385	130
				11										4										485	650	365	110
				15										4										525	680	390	130
	280		7.5	6	485	600	370	110																			
			11	6	525	650	385	130																			
			7.5	6	485	680	360	110																			
	230		11	6	525	740	400	130																			
			18.5	4	575	650	620	195																			
			22	4	575	680	620	195																			
	S 5		350	30	4	445	400	16	25	53	85	850	708	1000										615	710	660	225
				18.5	4																			575	710	630	195
				22	4																			575	740	630	195
		280	30	4	615										790	670	225										
			5	6	575										680	620	195										
			18.5	6	615										710	660	195										
		230	22	6	615										740	660	225										
			15	6	575										790	640	195										
			18.5	6	615										830	670	225										
				22	6										615	860	680	225									

*:ミキサー本体概算質量には、モータの質量が含まれています。ミキシングシャフト・インペラの質量は含まれていません。
 *:表中、C・M・Jの寸法および概算質量は安川製全閉外扇屋外形モータにて算出しています。これらの値はモータの銘柄・仕様によって異なります。
 サタケでは、つねに品質改善につとめていますので、製品の形や仕様が異なる場合があります。あらかじめご了承ください。